

# PRODUCT

## VTS 258 DUAL -86°C ULTRA LOW TEMP. FREEZERS

VTS 258 DUAL features a rare combination of streamlined and space-saving design with large capacity and state-of-the-art technology.

A large control panel displays temperature history, which can be downloaded via the integrated USB port. The exclusive cabinet also features door alarm, high/low alarm and 50h battery backup.

### SPECIFICATIONS

Gross volume, litres (cu. ft.)	253 (8.93)
Internal storage capacity, litres (cu. ft.)	221 (7.80)
Temperature range (16°C-25°C AMB)	-60°C to -86°C
Temperature probes	1
Compressor	Dual Embraco
Refrigerant	Nature-R
Noise level, dB	60
Power consumption @ 25°C AMB, kWh / 24h	9,0
Power consumption, kWh / year	3.285
Voltage, V	220-240
Frequency, Hz	50

### FEATURES

Castors	4
Inner doors	2
Defrost	Manual
Battery Backup	50h
USB	YES
Data connection	MODBUS
Digital controller	XW737K
Data logging, # logs	35.000
Analogue chart recorder	Optional
Adjustable shelves, stainless, pcs.	5



### DIMENSIONS

Height, mm (inches)	1.985 (78.14)
Height w. castors, mm (inches)	2.055 (80.90)
Width, mm (inches)	600 (23.62)
Depth, mm (inches)	580 (22.83)
Depth w. handle + evap., mm (inches)	707 (27.83)
Gross weight, kg (lbs)	135 (297)
Net weight, kg (lbs)	122 (269)

### LOADING QUANTITIES

Qty. per 20' / 40' container	24 / 51
Qty. per truck (EU standard)	60

Products are subject to change due to enhancements and continuous development. Vestfrost Solutions reserve the right to alter any information, without further notice.



**BIOMEDICAL SOLUTIONS**

**VESTFROST**  
SOLUTIONS



**VONMARCKEN**  
LABORATORY & MEDICAL EQUIPMENT

# DETAILS

## VTS 258 DUAL -86°C ULTRA LOW TEMP. FREEZERS

- State-of-the-art unit designed and manufactured by A/S Vestfrost in Denmark
- Unit optimized for optimal footprint
- DUAL compressor system with improved cooling capacity
- Maintains -60°C with only 1 compressor running



**SAFETY** first, and therefore the VTS units are all equipped with integrated locks, alarms and USB port for data transfer.

## ENVIRONMENT

- Eco-friendly, HCFC-free Nature R refrigerant
- Efficient cyclopentane insulation
- Low energy consumption

## FEATURES

- Digital XW737K controller with display
- Approximately 50 hours battery backup
- Prepared for external logging equipment
- Top LED light for maximum visibility
- Top-quality castors for explicit movability
- Integrated lock to prevent unauthorized access
- High/low temperature alarm



**PRECISION** digital XW737K controller with display, on-screen graph, audible and visual alarm.

## QUALITY

- User-friendly and maintenance-free
- Dual compressor system
- Galvanized, pre-painted steel cabinet
- ISO 9001, 14001 & 18001 OHSAS Certified



**TOP-QUALITY** castors eases repositioning of the VTS line units.

Products are subject to change due to enhancements and continuous development. Vestfrost Solutions reserve the right to alter any information, without further notice.



BIOMEDICAL SOLUTIONS

**VESTFROST**  
SOLUTIONS

  
**VONMARCKEN**  
LABORATORY & MEDICAL EQUIPMENT

# DIMENSIONS

## VTS 258 DUAL

-86°C ULTRA LOW TEMP. FREEZERS

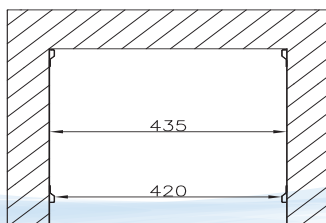
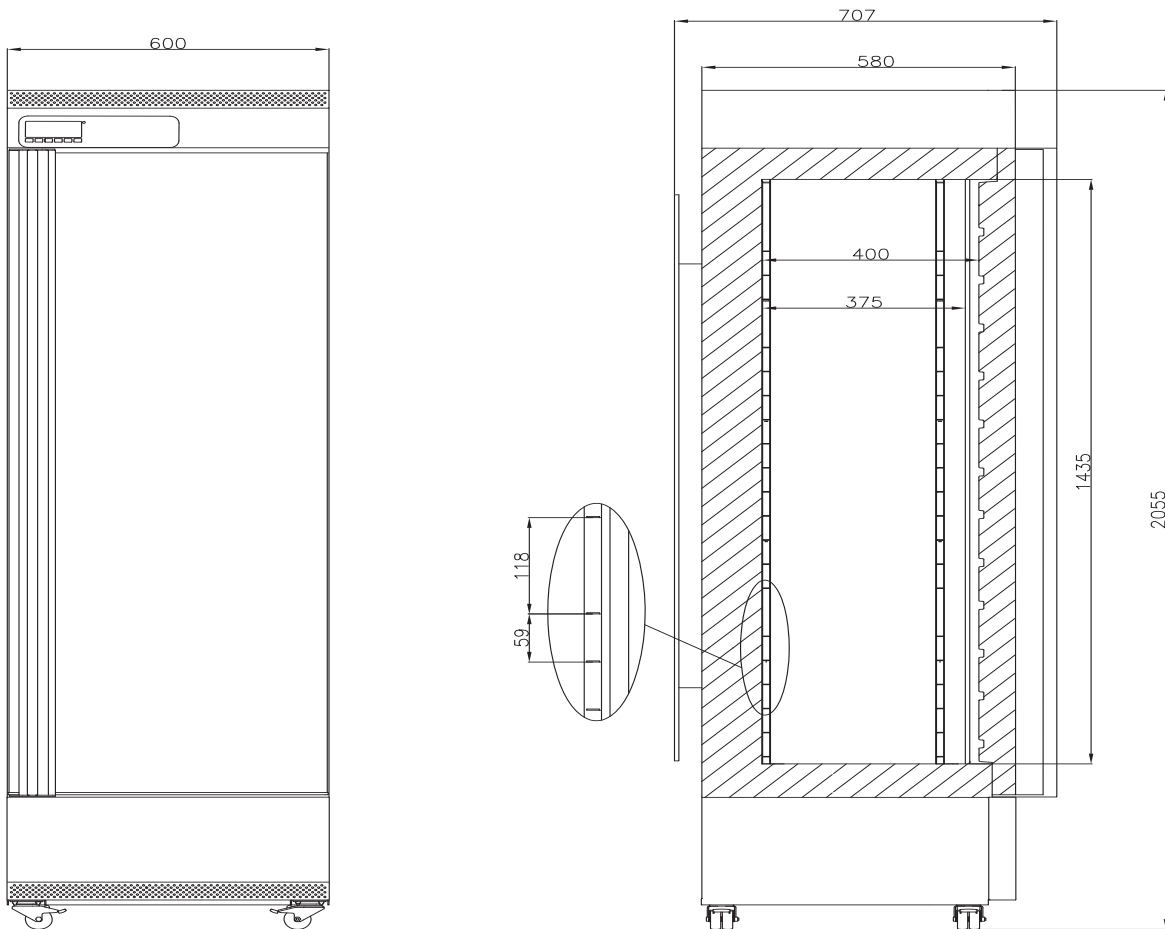

All measurements in mm

### DIMENSIONS

Height, mm (inches)	1.985 (78.14)
Height w. castors, mm (inches)	2.055 (80.90)
Width, mm (inches)	600 (23.62)
Depth, mm (inches)	580 (22.83)
Gross weight, kg (lbs)	135 (297)

Products are subject to change due to enhancements and continuous development. Vestfrost Solutions reserve the right to alter any information, without further notice.



BIOMEDICAL SOLUTIONS

**VESTFROST**  
SOLUTIONS

**VONMARCKEN**  
LABORATORY & MEDICAL EQUIPMENT

# DIMENSIONS

## VTS 258 DUAL

-86°C ULTRA LOW TEMP. FREEZERS

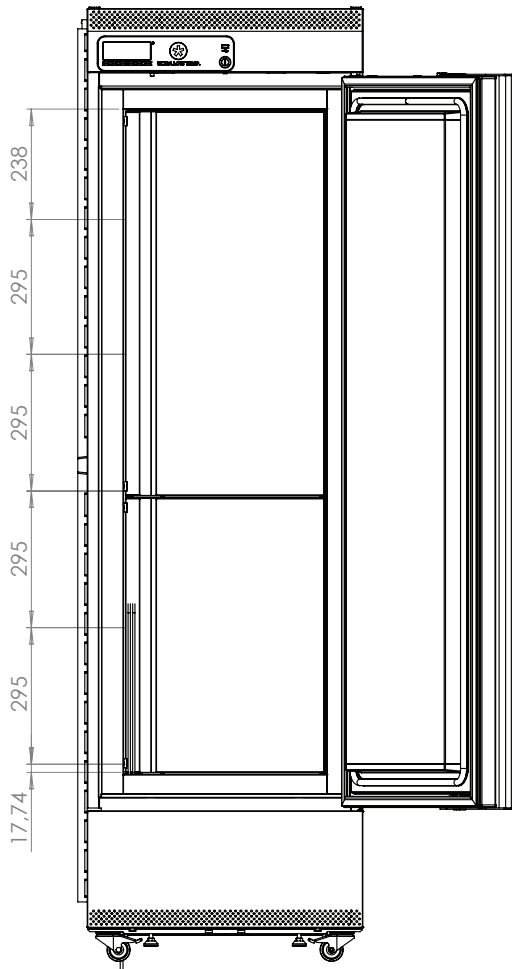

### INTERNAL DIMENSIONS

Height, mm (inches)	1.420 (55,90)
Width, mm (inches)	435 (17,12)
Depth, mm (inches)	370 (14,56)
Insulation, mm	80
Insulation type	PUR
Internal humidity, %	<5

### LOADING CAPACITY

Max loading, shelves, kg (lbs)	15
Max loading, total, kg (lbs)	75
Shelf material	Stainless

### UNIT FEATURES

Porthole for external probe, mm Ø	NO
Adjustable shelves, pcs	5
Castors (with brakes)	4 (4)
Inner doors	2
Door vacuum release	Automatic

### STORAGE CAPACITY

Vials, 50mm boxes, pcs	11.664
Vials, 75mm boxes, pcs	6.804
Vials, 100mm boxes, pcs	4.860

Products are subject to change due to enhancements and continuous development. Vestfrost Solutions reserve the right to alter any information, without further notice.



BIOMEDICAL SOLUTIONS

**VESTFROST**  
SOLUTIONS

**VONMARCKEN**  
LABORATORY & MEDICAL EQUIPMENT