

Model KBF 720 | Constant climate chambers with a large temperature / humidity range

The proven specialist for reliable ICH stability tests in the pharmaceutical industry: the KBF masters all long-term tests, accelerated tests and stress tests. It fulfills all important ICH requirements, from precision to programming and documentation. With flexible water supply options for all installation locations. In addition, the new KBF consumes up to 40 % less energy than its predecessor. With optional light modules, the KBF can be converted into an ICH photostability chamber and a plant growth chamber.



Model 720



Model 720

IMPORTANT FEATURES

- Temperature range: 0°C to +70°C
- Humidity range: 10% to 80% RH
- Proven APT.line™ preheating chamber technology
- Up to 40% lower energy consumption compared to the previous model
- Energy-efficient cooling with modern inverter cooling unit
- Cooling with climate-neutral R-600a refrigerant
- Door heating to prevent condensation
- Adjustable fan speed
- Humidity regulation with capacitive humidity sensor and responsive steam humidification
- Housing design with HIT technology
- Stainless-steel inner chamber
- Inner doors made of metal oxide-coated safety glass
- Two racks made of stainless steel
- Large access port with silicone plug
- Floor-standing units featuring robust twin casters with brakes at the front
- Stackable tabletop units with a volume of up to 130 liters
- Intuitive touchscreen controller with time-segment and real-time programming
- Ergonomically adjustable control terminal (for units with a volume of 470 liters and above)
- Signal triangle with light-up status display (for units with a volume of 470 liters and above)
- Internal data logger, measured values can be read out in open format via USB
- Class 3.3 independent temperature safety device (DIN 12880) with visual and acoustic alarms
- Unit self-test for comprehensive status analysis
- Data interfaces: Ethernet, USB
- BINDER Multi Management Software APT-COM™ basic edition
- Optional light modules for ICH photostability testing (for models 260, 470, 720)
- Optional LED light modules for plant growth (for models from 260)

ORDERING INFORMATION

| Interior volume [L] | Power supply - unit fuse | Plug* | Version | Model version | Art.-No. |
|----------------------|---------------------------------|-----------|----------|---------------|-----------|
| Model KBF 720 | | | | | |
| 727 | 220...240 V 1~ 50/60 Hz -16,0 A | CEE 7/7 | Standard | KBF720-230V | 9020-0481 |
| | 120 V 1~ 50/60 Hz -16,0 A | NEMA 5-20 | Standard | KBF720UL-120V | 9020-0497 |

TECHNICAL DATA

| Data | | |
|---|--------------|---------------|
| Designation | KBF720-230V | KBF720UL-120V |
| Article Number | 9020-0481 | 9020-0497 |
| Option model | Standard | Standard |
| Performance Data Temperature | | |
| Temperature range | 0...70 °C | 0...70 °C |
| Max. heat compensation at 40°C | 640 W | 640 W |
| Performance Data Climate | | |
| Temperature range with humidity | 10...70 °C | 10...70 °C |
| Humidity range | 10...80 % RH | 10...80 % RH |
| Temperature uniformity at 25°C and 60% RH | 0.3 ± K | 0.3 ± K |
| Temperature uniformity at 40°C and 75% RH | 0.2 ± K | 0.2 ± K |
| Temperature fluctuation at 25°C and 60% RH | 0.1 ± K | 0.1 ± K |
| Temperature fluctuation at 40°C and 75% RH | 0.1 ± K | 0.1 ± K |
| Recovery time after door was opened for 30 s at 25°C and 60% RH | 1 min | 1 min |
| Recovery time after door was opened for 30 s at 40°C and 75% RH | 5 min | 5 min |
| Electrical data | | |
| Rated Voltage | 220...240 V | 120 V |
| Power frequency | 50/60 Hz | 50/60 Hz |
| Nominal power | 1,6 kW | 1,6 kW |
| Unit fuse | 16,0 A | 16,0 A |
| Phase (Nominal voltage) | 1~ | 1~ |
| Dimensions and weights | | |
| Interior volume | 727 L | 727 L |
| Net weight of the unit (empty) | 298 kg | 298 kg |
| Load per rack | 40 kg | 40 kg |
| Permitted load | 100 kg | 100 kg |
| Wall clearance back | 100 mm | 100 mm |

| | | |
|---|----------|----------|
| Wall clearance sidewise | 180 mm | 180 mm |
| Housing dimensions not incl. fittings and connections | | |
| Width net | 1,285 mm | 1,285 mm |
| Height net | 1,951 mm | 1,951 mm |
| Depth net | 900 mm | 900 mm |
| Internal Dimensions | | |
| Interior width | 1,011 mm | 1,011 mm |
| Interior height | 1,250 mm | 1,250 mm |
| Interior depth | 575 mm | 575 mm |
| Inner doors | 2 | 2 |
| Unit doors | 2 | 2 |
| Environment-specific data | | |
| Energy consumption at 25°C and 60% RH | 360 Wh/h | 385 Wh/h |
| Energy consumption at 40°C and 75% RH | 360 Wh/h | 440 Wh/h |
| Fixtures | | |
| Number of shelves (std./max.) | 2/16 | 2/16 |

All technical data is specified for unloaded units with standard equipment at an ambient temperature of $+22\text{ °C} \pm 3\text{ °C}$ and a power supply voltage fluctuation of $\pm 10\%$. The temperature data is determined in accordance to BINDER factory standard following DIN 12880, observing the recommended wall clearances of 10 % of the height, width, and depth of the inner chamber. Technical data refers to 100 % fan speed. All indications are average values, typical for units produced in series. We reserve the right to change technical specifications at any time.

DIMENSIONS Incl. fittings and connections [mm]

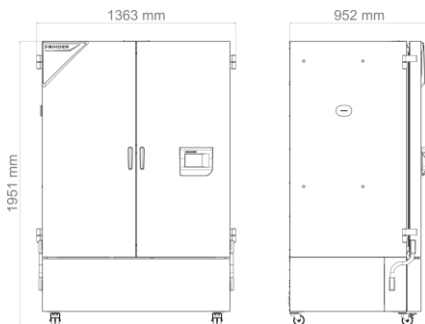

DIAGRAMS

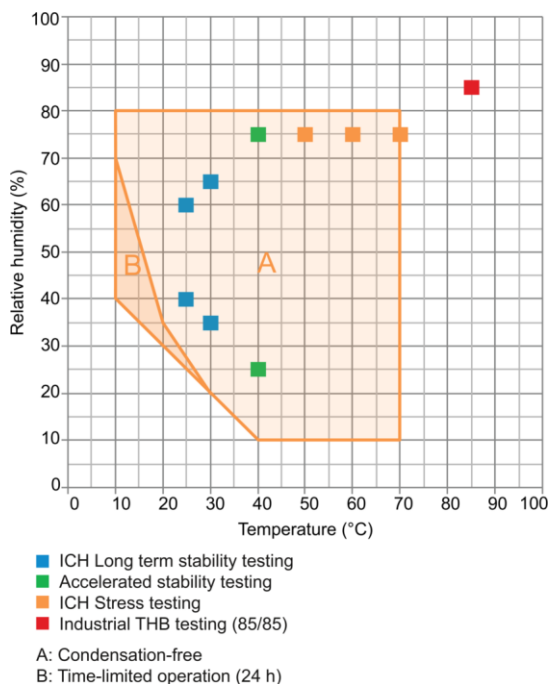

Climate chart

OPTIONS

| Designation | Description | KBF 720 | * | Art.-No. |
|--------------------------------|---|---------|----|-----------|
| | left | | | |
| | 30 mm | • | 01 | 8012-2481 |
| | 50 mm | • | 01 | 8012-2482 |
| | 100 mm | • | 01 | 8012-2483 |
| | right | | | |
| | 30 mm | • | 01 | 8012-2484 |
| Access port with silicone plug | 50 mm | • | 01 | 8012-2485 |
| | 100 mm | • | 01 | 8012-2486 |
| | top | | | |
| | 30 mm | • | 01 | 8012-2499 |
| | 50 mm | • | 01 | 8012-2487 |
| | 100 mm | • | 01 | 8012-2488 |
| Alarm output, zero-voltage | Accessible via 3-pin clamping sleeve (max. 24 V - 2.5 A), with acoustic signal that can be switched off | • | - | 8012-2503 |

| Designation | Description | KBF 720 | * | Art.-No. |
|---|---|---------|---|-----------|
| Analog output 4-20 mA | for temperature and humidity values (output not adjustable) | • | - | 8012-2574 |
| Calibration certificate, expanded | for temperature and humidity; for extending the measurement in center of chamber to include another test value | • | - | 8012-2575 |
| Calibration certificate, temperature | temperature measurement incl. certificate, 9 measuring points at specified temperature | • | - | 8012-2378 |
| | temperature measurement incl. certificate, 15- 18 measuring points at specified temperature | • | - | 8012-2382 |
| | temperature measurement incl. certificate and 27 measuring points at specified temperature | • | - | 8012-2426 |
| Calibration certificate, temperature and humidity | Measurement in center of chamber at 25°C / 60% RH or at specified test values | • | - | 8012-2437 |
| | temperature (according to DIN12880) and humidity measurement incl. certificate, 27 temperature measuring points and 1 humidity measuring point, at 25 °C / 60 % RH or at specified values | • | - | 8012-2577 |
| Door lock | lockable door handle | • | - | 8012-2536 |
| Door lock, electromechanical | can be opened with PIN code via controller | • | - | 8012-2589 |
| Inner chamber, reinforced | max. total load 200 kg | • | - | 8012-2521 |
| Interior lighting | With climate-resistant LEDs, switches when the unit door is opened | • | - | 8012-2565 |
| Shipping pallet | with unloading ramp for installing unit without forklift | • | - | 8012-2547 |
| Specimen temperature display | Flexible Pt 100 indoor temperature sensor, for object temperature display or control | • | - | 8012-2591 |
| Swivel casters, height-adjustable | For horizontal alignment of the unit on uneven floors | • | - | 8012-2543 |

ACCESSORIES

| Designation | Description | KBF 720 | * | Art.-No. |
|---------------------------------------|--|---------|---|-----------|
| APT-COM™ 4 GLP-Edition | for working under GLP-compliant conditions. Measured values are documented in a tamper-proof way in line with the requirements of FDA Regulation 21 CFR 11. | | | |
| | version 4, GLP edition | • | - | 9053-0042 |
| APT-COM™ 4 PROFESSIONAL-Edition | convenient unit and user management built on the BASIC edition. Suitable for networking up to 100 units. | | | |
| | version 4, PROFESSIONAL edition | • | - | 9053-0040 |
| BINDER PURE AQUA SERVICE | System for preparation or complete desalination of tap water, complete set containing PURE AQUA 300 single-use cartridge, measuring device, and all necessary connecting parts | • | - | 8012-0759 |
| BINDER PURE AQUA SERVICE, accessories | Single-use, replacement cartridge for BINDER PURE AQUA System | • | - | 6011-0165 |
| CO ₂ gassing module | BINDER CO ₂ gassing module 0-1%, with NDIR CO ₂ sensor and analog output 4-20 mA | • | - | 8012-2140 |
| | BINDER CO ₂ gassing module 0-20%, with NDIR CO ₂ sensor and analog output 4-20 mA | • | - | 8012-2138 |

| Designation | Description | KBF 720 | * | Art.-No. |
|---------------------------|---|---------|---|-----------|
| ICH light module | BINDER ICH-Q1B light module consisting of a VIS cassette and a UVA cassette as well as an independent power supply | • | - | 8012-2442 |
| ICH light module with LQC | BINDER ICH-Q1B light module with light-dose control consisting of a VIS cassette, a UVA cassette, a spherical VIA sensor, a spherical UVA sensor as well as an independent power supply | • | - | 8012-2444 |
| LED light bars | Basic set consisting of 2 pieces, attachment material, control unit for max. 4 light strips, 100-240 V, 50/60 Hz | | | |
| | Basic set 500, length 50 cm | • | - | 8012-1108 |
| | Basic set 900, length 90 cm | • | - | 8012-1109 |
| | Expansion set consisting of 2 pieces, attachment material: clips. For expanding the basic set of light bars | | | |
| | Expansion set 500, length 50 cm | • | - | 8012-1717 |
| | Expansion set 900, length 90 cm | • | - | 8012-1718 |
| Light module for plants | BINDER LED plant light module consisting of 16 LED strip lights, 3-channel controller and fresh air pump as well as independent power supply | • | - | 8012-2439 |
| pH-neutral detergent | concentrated, for gentle remove of residual contaminants; 1 kg | • | - | 8012-2250 |
| Qualification documents | IQ/OQ/PQ documents – supporting documents for validation performed by customers, according to customer requirements, PQ section added to qualification folder IQ/OQ; parameters: temperature and humidity values | | | |
| | Digital in PDF format | • | - | 7057-0006 |
| | Hard copy inside folder | • | - | 7007-0006 |
| | IQ/OQ documents – supporting documents for validation performed by customers, consisting of: IQ/OQ checklists incl. calibration guide and comprehensive unit documentation; parameters: temperature and humidity values | | | |
| | Digital in PDF format | • | - | 7057-0002 |
| | Hard copy inside folder | • | - | 7007-0002 |
| Reinforced rack | Shelf rack in set with pair of retaining rails (U rails), made entirely of stainless steel | | | |
| | Load-bearing capacity 80 kg | • | - | 8012-2414 |
| Shelf rack, perforated | Shelf rack in set with pair of retaining rails (U rails), made entirely of stainless steel | | | |
| | Load-bearing capacity 40 kg | • | - | 8012-2408 |
| Standard rack | Shelf rack in set with pair of retaining rails (ball bearing mounted telescopic rails), made entirely of stainless steel | | | |
| | Load-bearing capacity 40 kg | • | - | 8012-2385 |
| | Shelf rack in set with pair of retaining rails (U rails), made entirely of stainless steel | | | |
| | Load-bearing capacity 40 kg | • | - | 8012-2391 |

| Designation | Description | KBF 720 | * | Art.-No. |
|--------------|---|---------|---|-----------|
| Water supply | External, free-standing, set consisting of 20-liter fresh water canister with pump and level sensor and 20-liter waste water canister | • | - | 8012-2592 |

SERVICES

| Designation | Description | * | Art.-No. |
|---|--|---|-----------|
| Calibration services | | | |
| Temperature and humidity calibration | Expansion –Temperature and humidity calibration with 1 measuring point in center of chamber with 1 specified pair of values, including certificate | – | DL30-0302 |
| | Temperature and humidity calibration with 1 measuring point in center of chamber with 1 specified pair of values, including certificate | – | DL30-0340 |
| Temperature and humidity measurement, 9-1 measuring points | Temperature measurement with 9 temperature measuring points and 1 humidity measuring point in center of chamber with a pair of values specified by the user, including certificate | – | DL30-0309 |
| Temperature and humidity measurement, 18-1 measuring points | Temperature measurement with 18 temperature measuring points and 1 humidity measuring point in center of chamber with a pair of values specified by the user, including certificate | – | DL30-0318 |
| Temperature and humidity measurement, 27-1 measuring points | Temperature measurement with 27 temperature measuring points and 1 humidity measuring point in center of chamber with a pair of values specified by the user, including certificate | – | DL30-0327 |
| Temperature and humidity measurement according to DIN12880 | Temperature measurement in accordance with DIN 12880 with 27 temperature measuring points and 1 humidity measuring point in center of chamber with a pair of values specified by the user, including certificate | – | DL30-0427 |
| Installation services | | | |
| Unit commissioning | Connect the unit to the customer-side connections (electricity, water, wastewater, gas), basic functions check, brief operating instructions. (excl.: unpacking, setup, controller instructions, programming, installation work) | – | DL10-0300 |
| Unit instructions | Instruction regarding operating principle and basic functions of the unit, operation of the control electronics including programming | – | DL10-0700 |
| Maintenance contracts | | | |
| BRONZE 3-year maintenance contract | Maintenance service as contractually agreed, visual inspection of mechanical and electrical components, check of control response, 20% discount on spare parts | – | DL20-0710 |
| GOLD 3-year maintenance contract | Maintenance service as contractually agreed, visual inspection of mechanical and electrical components, check of control response, 20% discount on spare parts, testing of all key functions, replacement of wear parts, calibration of one temperature/humidity value, including certificate | – | DL20-0920 |
| SILVER 3-year maintenance contract | Maintenance service as contractually agreed, visual inspection of mechanical and electrical components, check of control response, 20% discount on spare parts, testing of all key functions, calibration of one test temperature specified by the user in the center of the usable space, without certificate | – | DL20-0820 |
| Maintenance services | | | |
| Maintenance | One-off maintenance service in accordance with maintenance schedule. Visual inspection of mechanical and electrical components, testing of all key functions. Calibration of a test temperature specified by the user in center of usable space without certificate | – | DL20-0613 |
| Validation services | | | |
| Execution of IQ/OQ | Execution of IQ/OQ in accordance with qualification folder | – | DL42-0300 |

| Designation | Description | * | Art.-No. |
|---------------------------|--|---|-----------|
| Execution of IQ/OQ/PQ | Execution of IQ/OQ/PQ in accordance with qualification folder | – | DL44-0500 |
| Warranty service | | | |
| 1-year warranty extension | The warranty is extended by 1 year from the delivery date, wear parts are excluded | – | DL50-0030 |

NOTES

01 Condensation may occur in the area around the access port. Access ports may be placed in custom locations for an additional charge.

BINDER GmbH
Tuttlingen, Germany
TEL +49 7462 2005 0
info@binder-world.com
www.binder-world.com

BINDER Inc.
Bohemia, NY, USA
TEL +1 631 224 4340
usa@binder-world.com
www.binder-world.us

BINDER Environmental Testing
Equipment (Shanghai) Co., Ltd.
Shanghai, P.R. China
TEL +86 21 685 808 25
china@binder-world.com
www.binder-world.com

BINDER Asia Pacific (Hong Kong) Ltd.
Kowloon, Hong Kong, P.R. China
TEL +852 39070500
asia@binder-world.com
www.binder-world.com